

Spring Set Holding Brakes

Model 308



SPRING SET HOLDING BRAKE

Model 308

- Factory Assembled and Tested
- Spline Drive

Customer Shall Maintain:

The concentricity between mounting flange and shaft within .010;
the perpendicularity between mounting surface and shaft within .010.

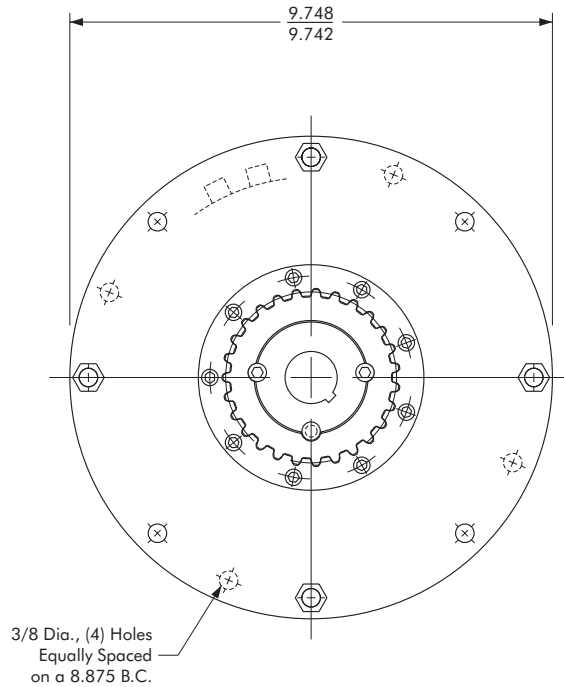
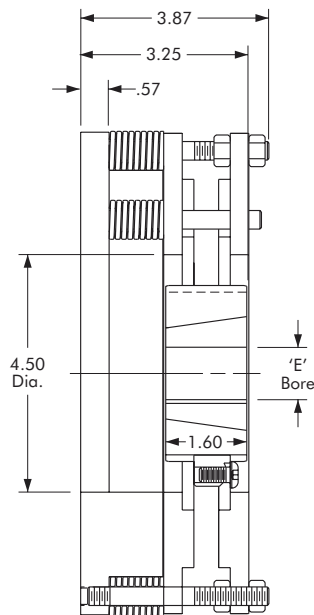

Technical Data

MODEL NO.	WEIGHT LBS.	STATIC TORQUE IN. LBS.	COIL VOLTAGE VDC	*RATED CURRENT AMPS
308	21	1200	90	.59

* Rated Current for 90v.

Bushing 1615

BORE "E"		KEYWAY	PART NO.
1/2"	.500	.125 x .062	326015 - 1
9/16"	.562	.125 x .062	326015 - 2
5/8"	.625	.187 x .093	326015 - 3
11/16"	.687	.187 x .093	326015 - 4
3/4"	.750	.187 x .093	326015 - 5
13/16"	.812	.187 x .093	326015 - 6
7/8"	.875	.187 x .093	326015 - 7
15/16"	.937	.250 x .125	326015 - 8
1"	1.000	.250 x .125	326015 - 9
1-1/16"	1.062	.250 x .125	326015 - 10
1-1/8"	1.125	.250 x .125	326015 - 11
1-3/16"	1.187	.250 x .125	326015 - 12
1-1/4"	1.250	.250 x .125	326015 - 13
1-5/16"	1.312	.312 x .156	326015 - 14
1-3/8"	1.375	.312 x .156	326015 - 15
1-7/16"	1.437	.375 x .187	326015 - 16
1-1/2"	1.500	.375 x .187	326015 - 17
1-9/16"	1.562	.375 x .187	326015 - 18
1-5/8"	1.625	.375 x .187	326015 - 19
1-3/8"	1.375	.375 x .125	326015 - 20
1-5/8"	1.625	.375 x .125	326015 - 21

Order Parts for Assembly No. FC308069

ITEM	QTY.	DESCRIPTION	MODEL NO. 308
1	1	Armature Hub	308680
M	1	Spring Set Holding Brake 24 Volts 90 Volts	308070-3 308070-4
E	1	Taper Bushing (1615)	326015-XX

To order, specify: 1, Armature Hub
1, Spring Set Holding Brake of required voltage
1, Bushing plus bore size.