

Spring Set Holding Brakes

Model 303HQ



SPRING SET HOLDING BRAKE

Model 303HQ

- Factory Assembled and Tested
- Spline Drive
- Double Disc

Customer Shall Maintain:

The concentricity between mounting flange and shaft within .006; the perpendicularity between mounting surface and shaft within .006.

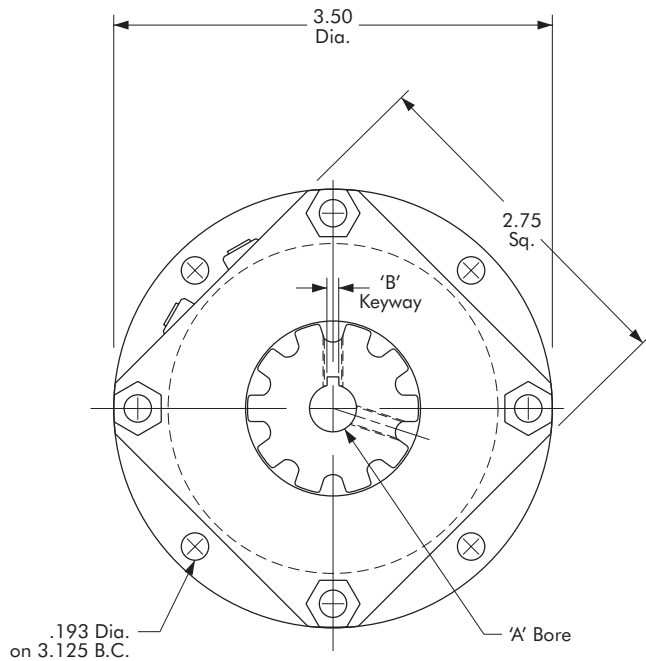
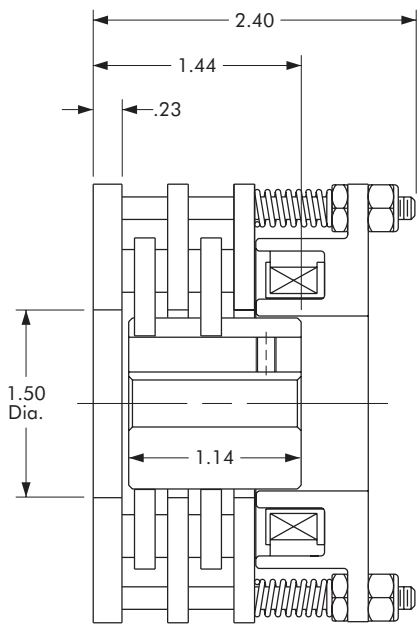

Technical Data

MODEL NO.	WEIGHT LBS.	STATIC TORQUE IN. LBS.	COIL VOLTAGE VDC	*RATED CURRENT AMPS
303HQ	2.12	60	90	.157

* Rated Current for 90v.

"A" Bore	"B" Keyway
1/2"	None
5/8"	.188 x .093
3/4"	.188 x .093

Order Parts for Assembly No. FC303071

ITEM	QTY.	DESCRIPTION	MODEL NO. 303HQ
A	1	Rotor Hub Assembly 1/2" Plain Bore 5/8" Bore 3/4" Bore	303466-DPB 303465-3 303465-4
M	1	Spring Set Holding Brake Double Disc 24 Volts 90 Volts	303072-3 303072-4

To order, specify: 1, Spring Set Holding Brake of required voltage
1, Rotor Hub Assembly of required bore size.