

Spring Applied Friction Brakes

Spring Applied Brakes – Type SAB

SAB SERIES SPRING APPLIED BRAKE

Manual Release Spring Applied Brake – Type SAB

Inertia Dynamics features a type SAB spring applied brake. SAB brakes are designed to be engaged and disengaged in a static condition at zero RPM. They are best used as parking brakes to hold loads in position. These brakes can be mounted to a flange or motor using thru-holes or tapped holes in the field cup. A conduit box is optional. SAB brakes have been used extensively for servo brake applications with minor modifications. High-temperature coil insulations are available upon request.

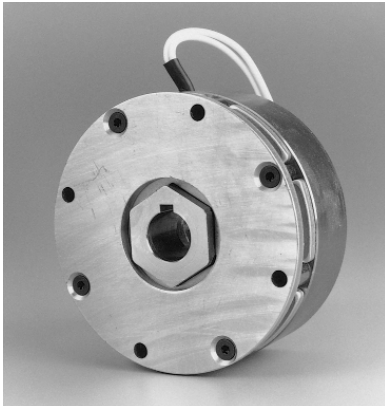

SAB90 Shown

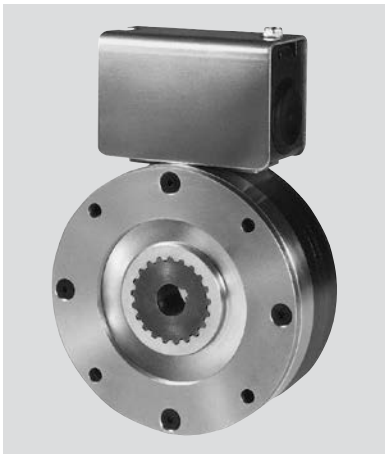

**SAB180 Shown with
Optional Conduit Box**

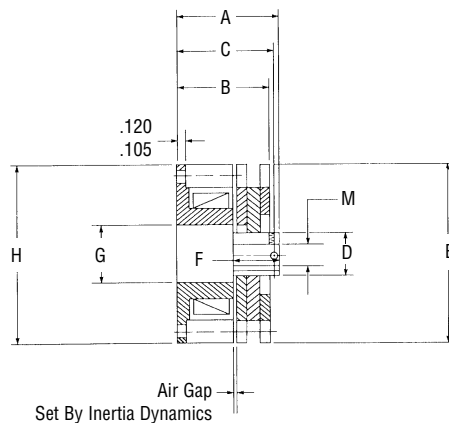

SAB20

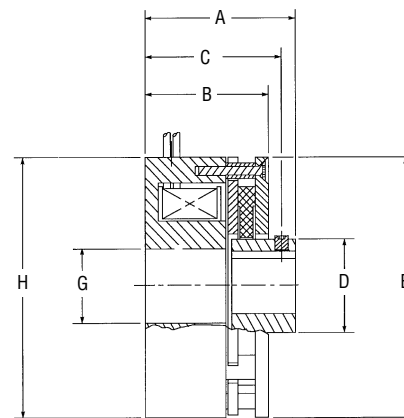
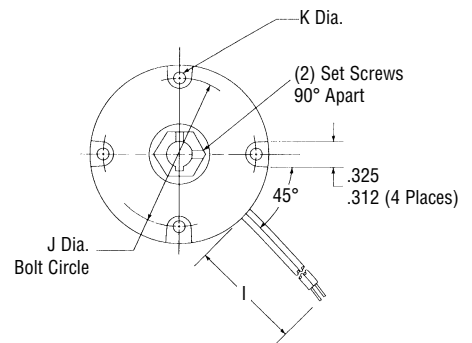

SAB90

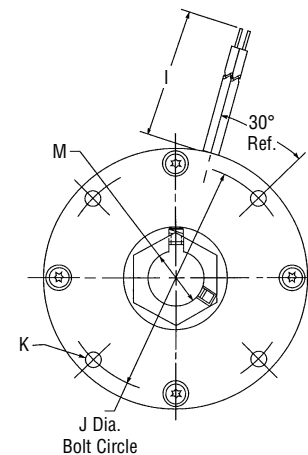

Spring Applied Friction Brakes

Spring Applied Brakes – Type SAB Imperial

Mechanical

MODEL NO.	STATIC TORQUE LB. - IN.	INERTIA LB. - IN. ² ARMATURE & HUB ASSEMBLY	WEIGHT LB.
SAB20	20	.018	1
SAB90	90	.130	3
SAB180	180	.312	5
SAB400	400	.748	7.1
SAB1200	1200	1.732	12.4

Electrical

MODEL NO.	90 VDC		24 VDC		12 VDC		120 VAC	
	AMPS	OHMS	AMPS	OHMS	AMPS	OHMS	AMPS	OHMS
SAB20	.098	922	.37	65	.72	16.7	.08	N.A.
SAB90	.17	534	.68	35.3	1.34	8.95	.13	N.A.
SAB180	.29	314	1.14	21.10	2.25	5.33	.25	N.A.
SAB400	.39	230	1.54	15.50	3.01	3.98	.33	N.A.
SAB1200	.58	156	2.27	10.60	4.51	2.66	.49	N.A.

Dimensions

MODEL NO.	HUB STYLE	A MAX.	B MAX.	C NOM.	D MAX.	E MAX.	F MIN.	G REF.	H MAX.	I ±.500	J NOM.	K DIA.	L	M BORES & KEYWAYS		
														BORE	NOMINAL KEYWAY	
															X**	Y**
SAB20	HEX	1.400	1.200	1.255	0.722	2.465	0.605	0.781	2.436	12.0	2.125	0.172	-	3/8	.094 - .097	.417 - .427
														5/16	.0625 - .0655	.347 - .352
														3/8	.094 - .097	.417 - .427
SAB90	HEX	1.938	1.658	1.753	1.298	3.530	0.740	1.375	3.530	18.0	3.125	0.190	#6 - 32 X .5	3/8	.094 - .097	.417 - .427
														1/2	.125 - .128	.560 - .567
														5/8	.1885 - .1905	.709 - .716
														3/4	.1885 - .1905	.836 - .844
SAB180	SPLINE	1.770	1.500	2.930	-	4.260	0.800	1.500	4.129*	-	3.75	0.223	#8 - 32 X .5	3/8	.094 - .097	.417 - .427
														1/2	.125 - .128	.560 - .567
														5/8	.1885 - .1905	.709 - .716
														3/4	.1885 - .1905	.836 - .844
														7/8	.1885 - .1905	.962 - .970
SAB400	SPLINE	1.940	1.500	2.930	-	5.010	0.800	1.770	4.514*	-	4.5	0.283	#10 - 24 X .5	1/2	.125 - .128	.560 - .567
														5/8	.1885 - .1905	.709 - .716
														3/4	.1885 - .1905	.836 - .844
														7/8	.1885 - .1905	.962 - .970
SAB1200	SPLINE	2.050	1.500	2.930	-	6.510	0.900	2.425	5.252*	-	5.875	0.409	1/4 - 20 X .5	1	.251 - .253	1.113 - 1.121
														1 1/8	.251 - .253	1.241 - 1.251
														1 1/4	.251 - .253	1.367 - 1.377
														1 3/8	.3135 - .3155	1.518 - 1.528
														1 1/2	.376 - .379	1.606 - 1.616

* Reference Dimension

** X denotes keyway width, Y denotes keyway height plus bore

Notes:

- SAB1200 – Special .375 x .250 key is supplied with unit. Mating shaft to have conventional ASA Standard Keyway.
- Conduit box is optional on models SAB180, 400 & 1200. Screw terminals supplied in place of conduit box.
- Consult factory for Zero Backlash Hub Style

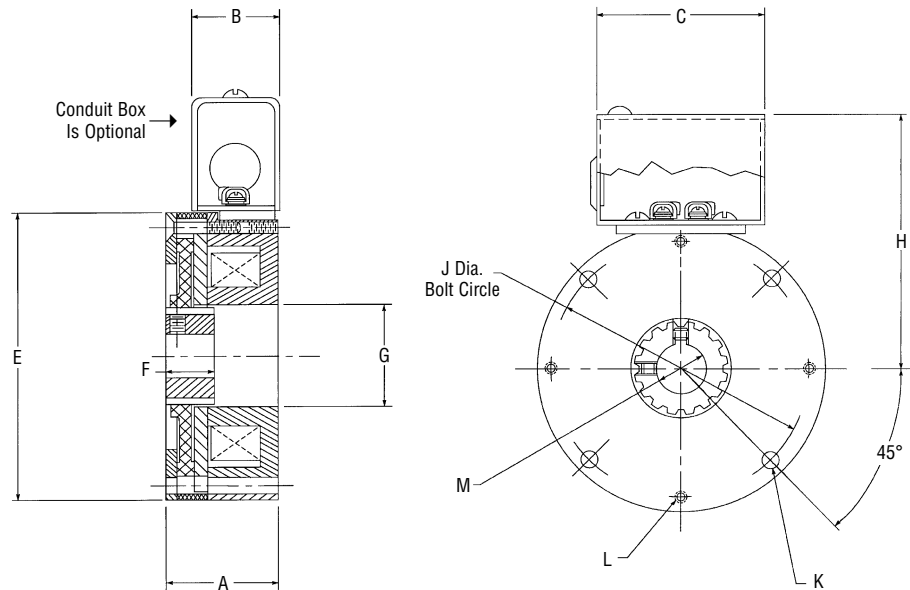

SAB180, 400, 1200

See page 29 for Ordering Information